



UMassAmherst

MIE 415 Fall 2008
Senior Capstone Design Project

Tube Bender Analysis and Redesign

Team 15
Eric Amato
Charlotte de Vries
Corey Hodges

Motivation

The model of tube bender analyzed was designed for use by small fabrication shops and for individual needs. This project was motivated by the desire to increase the marketability of such a tool by making it both a more cost effective investment and a lighter, more portable unit for shops and garages where floor space is an issue.

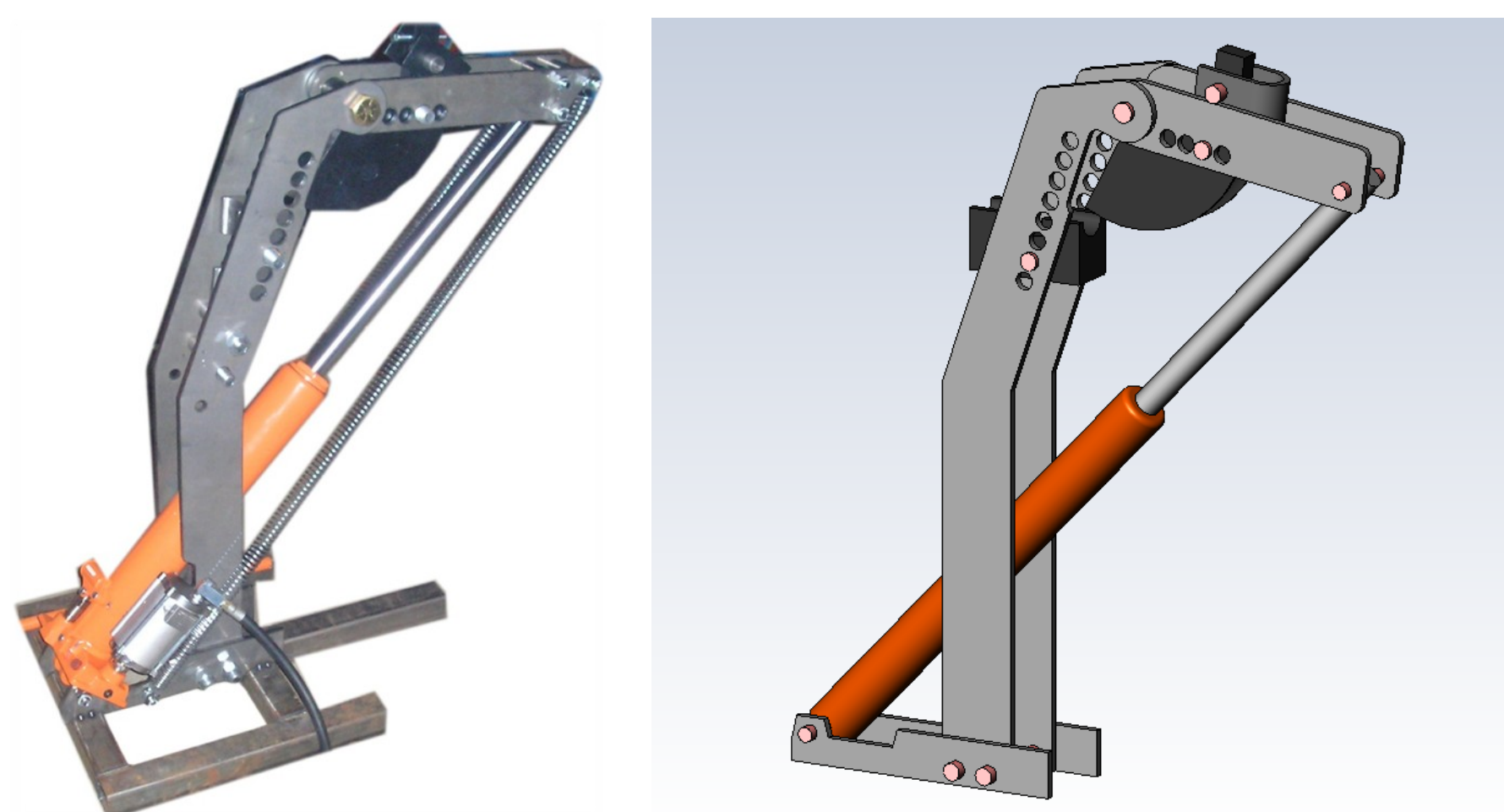

Finite Element Analysis

A finite element model was created in order to analyze the strengths of the original design. The analysis was conducted at the start of the tube bending process where the stresses are highest.

Forces were calculated through the use of Free Body Diagrams. These calculations demonstrated that the ram would be required to exert 4500 pounds of force to bend a nominally sized tube of 1.75 in. OD and 0.120 in. wall thickness.

Analysis was conducted using Ansys Workbench. Solid elements were used with a mesh size of 0.125 in.

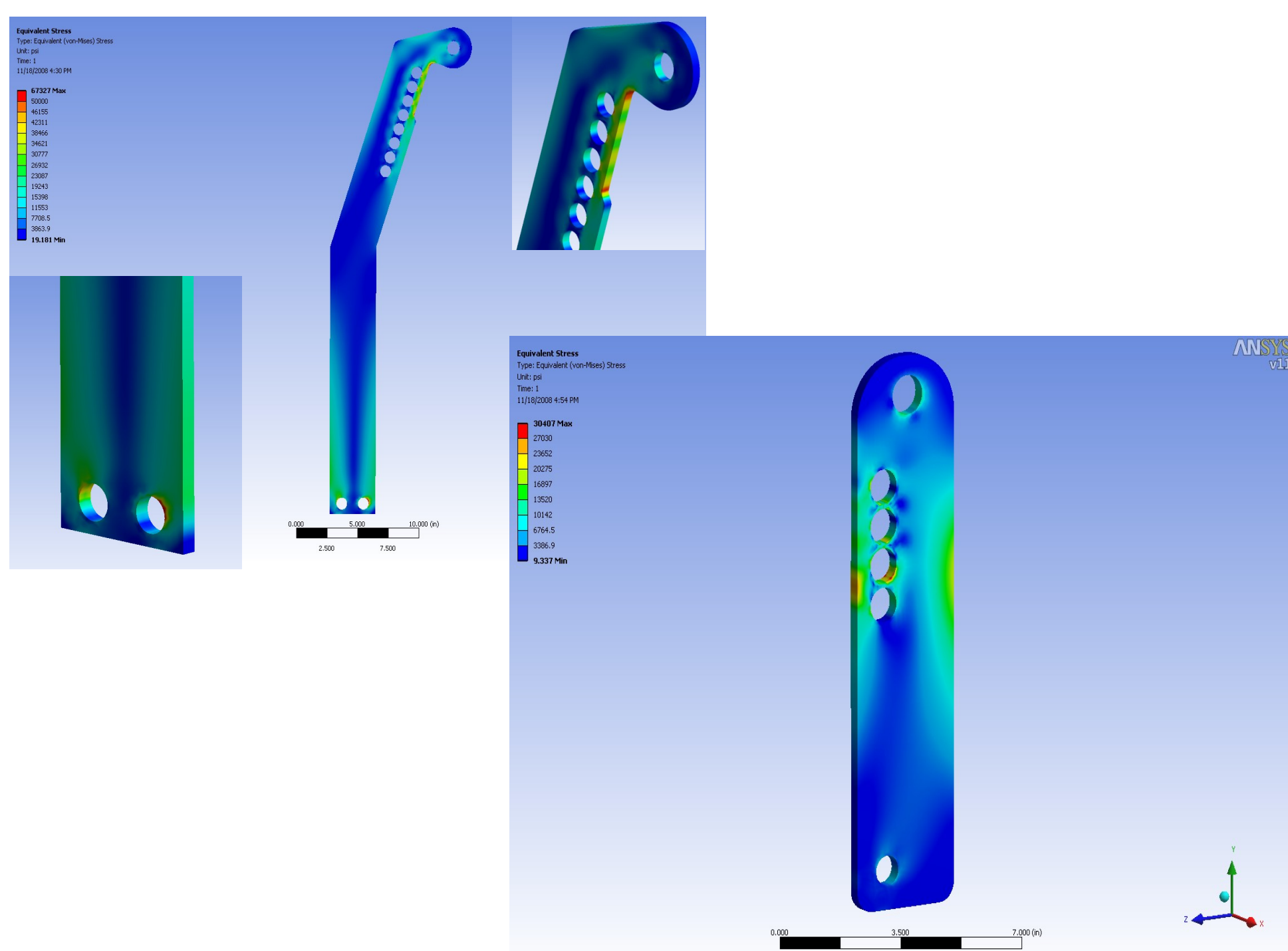

Model Validation

The tube bender strain was analyzed using a strain gauge at the points where the highest strain was estimated. The results below display strong agreement to the FEA analysis.

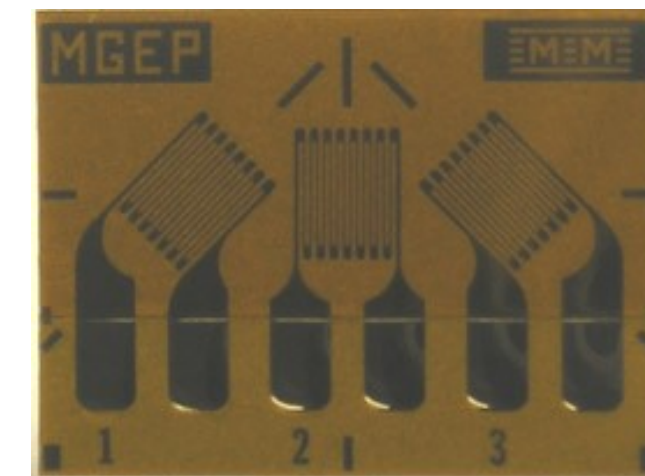

	Main Plate	Bending Arm
Strain Gauge 1	0.000430	-0.000192
Strain Gauge 2	0.001296	-0.000631
Strain Gauge 3	N/A	-0.000341
FEA Strain in direction of Strain Gauge 2	0.001113	-.000624

Redesign

Material was removed from the original design's low stress areas to reduce weight and save the manufacturer scrap steel costs in the amount of approximately \$5500/yr (assuming 7000 units sold per year). The 8 ton ram was replaced with a sufficient 3 ton ram. FEA was tested on redesigns at bend forces for maximal tolerance limits of tube size (0.073% of bends).

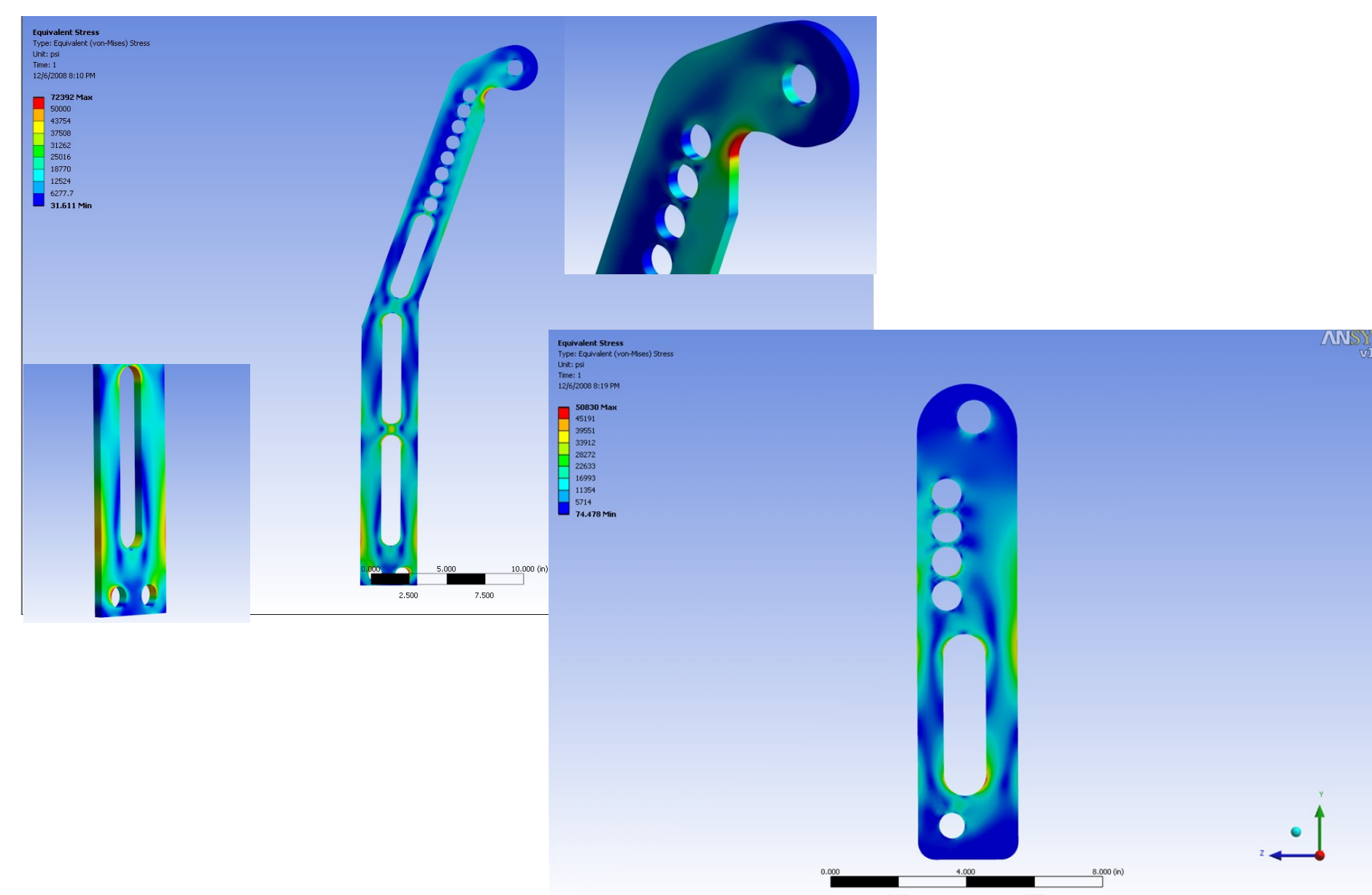

Component	Original Design		Redesign	
	Weight	Cost	Weight	Cost
Ram	37 lb	\$100.00	27.5 lb	\$45.00
Main Plate	13.8 lb	N/A	10.1 lb	\$0.75 saved per unit in scrap metal costs
Bending Arm	4.3 lb	N/A	3.3 lb	
Total for assembly	117.2 lb	\$500.00	98.3 lb	\$445.00

